

The unique
Rotary Lobe Pump
with MIP!



All Purpose Pump Installed in Various Applications!

Production, Supply and Waste Processes across all industries demand reliable and robust pump units.

The wide range of pump sizes, the option loaded modular design and the peripheral equipment enable Boerger to supply a suitable Rotary Lobe Pump for your pump application. Boerger pumps are manufactured to the European Explosion Proof Standard ATEX 100a.

The Boerger MIP-Design is a unique advantage to minimize downtime and maintenance: MIP (Maintenance In Place) allows the quick and convenient replacement of all fluid wetted parts without removal of pipes, drives or other components of the pump unit by your own staff.

Quick - Uncomplicated - Inexpensive.

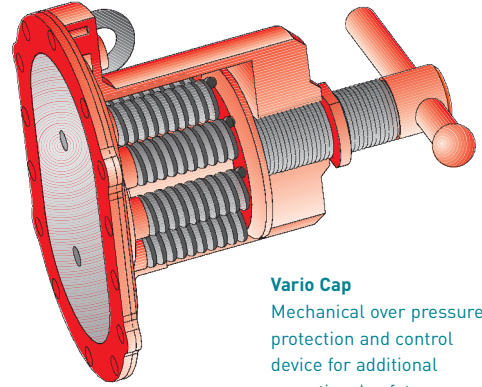

Vario Cap
Mechanical over pressure protection and control device for additional operational safety.

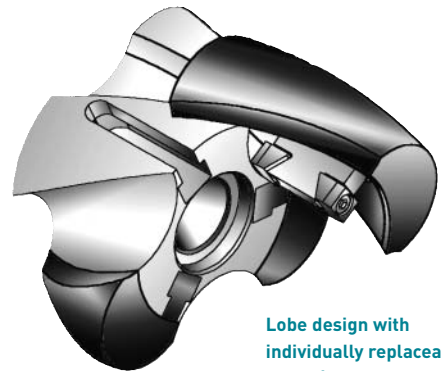

Lobe design with individually replaceable rotor tip
Uncomplicated maintenance and inexpensive repair with rotor tips.

Industrial fluids often include abrasive and aggressive characteristics. Wide viscosity ranges demand customized solutions for pumping systems: Boerger offers various shaft seals designs and rotor materials with different coatings (Elastomer, PTFE or Urethane) or solid stainless steel rotors. Casing protection plates are supplied with various steel, plastic or ceramic qualities.

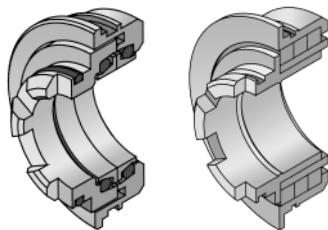

Shaft Seals
Quenched, reversible mechanical seal as standard, optional Multiseal or Packing.

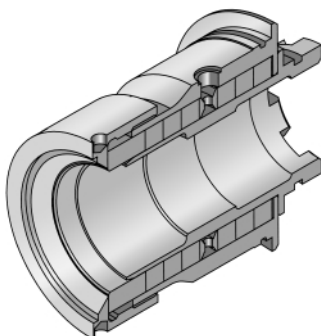

Worldwide unique
and exclusive from Boerger: Unrivalled MIP-Design reduces life cycle cost and downtime.





Resins in Coating Kitchen | A customer in the pulp and paper industry demanded a pump with dry run capabilities for liquid resins. Since maintenance friendliness was a priority a Boerger Rotary Lobe Pump with MIP Radial Liners was chosen as a customized solution. Result: Reliability and lower life cycle costs.

TECHNICAL SPECIFICATION

Pump Model PL 100	PL 100
Flow Rate	3 m ³ /h 13 usgpm
Pressure	6 bar 87 psi
Power	1,2 kW 3 HP



Lime Milk | Boerger delivered a Rotary Lobe Pump for lime milk to an industrial customer. Entirely coated rotors and Silicon Carbide mechanical seals are well suited for this demanding, abrasive application. Low rotation speed ensures longevity of the pump unit.

TECHNICAL SPECIFICATION

Pump Model PL 100	PL 100
Flow Rate	2-10 m ³ /h 9-44 usgpm
Pressure	3 bar 44 psi
Power	3 kW 4 HP



Chipped Bones in Acid Solution | In the Gelatine production process are low viscosity acid solutions (app pH 4) with chipped bones (narrow particle size spectrum) pumped. Low shear handling is a top priority. A Boerger Rotary Lobe Pump in Stainless Steel construction with minimized clearances does the job.

TECHNICAL SPECIFICATION

Pump Model PL 200	PL 200
Flow Rate	8 m ³ /h 35 usgpm
Pressure	2 bar 29 psi
Power	7,5 kW 10 HP



Wastewater | Centrifugal pumps feeding filters with lime saturated, neutralized wastewater had problems with lime settlement on the impeller and casing. The Boerger Rotary Lobe Pump discharges the fluid reliable and without problems.

TECHNICAL SPECIFICATION

Pump Model PL 200	PL 200
Flow Rate	30 m ³ /h 132 usgpm
Pressure	max. 4 bar 58 psi
Power	7,5 kW 10 HP



Adhesives | A packaging plant installed a Boerger Rotary Lobe Pump for viscous adhesives. Special priority is the function of the shaft seal that works in a discontinuous process. The pump is equipped with the Multiseal, a customized seal set up designed to handle coagulating materials.

TECHNICAL SPECIFICATION

Pump Model AL 50	AL 50
Flow Rate	4-5 m ³ /h 18-22 usgpm
Pressure	max. 2 bar 29 psi
Power	1,5 kW 2 HP



Molasses | An Australian Sugar Producer needed a maintenance friendly pump solution for molasses. Boerger supplied a side mounted Rotary Lobe Pump to prevent accumulation of crystalline phases in the pump body. The customer is very satisfied with the pump performance and the individually replaceable rotor tips and MIP Radial Liners.

TECHNICAL SPECIFICATION

Pump Model FL 518	FL 518
Flow Rate	80 m ³ /h 352 usgpm
Pressure	2 bar 29 psi
Power	11 kW 15 HP



Oil Sludge | Boerger Rotary Lobe Pumps are installed for clean up of soils contaminated by oil sludge lagoons. The contaminated soil is processed in a rotating drum burner. The high temperature of 150 °C (300 °F) requires FKM coated rotors.

TECHNICAL SPECIFICATION

Pump Model PL 300	PL 300
Flow Rate	36-70 m ³ /h 158-308 usgpm
Pressure	2,5 bar 36 psi
Power	15 kW 20 HP

BÖRGER®

Börger GmbH

Benningsweg 24

46325 Borken-Weseke

Germany

Phone +49 (0) 28 62 / 91 03-0

Fax +49 (0) 28 62 / 91 03-46

info@boerger-pumps.com

www.boerger-pumps.com

