

The unique
Rotary Lobe Pump
with MIP!

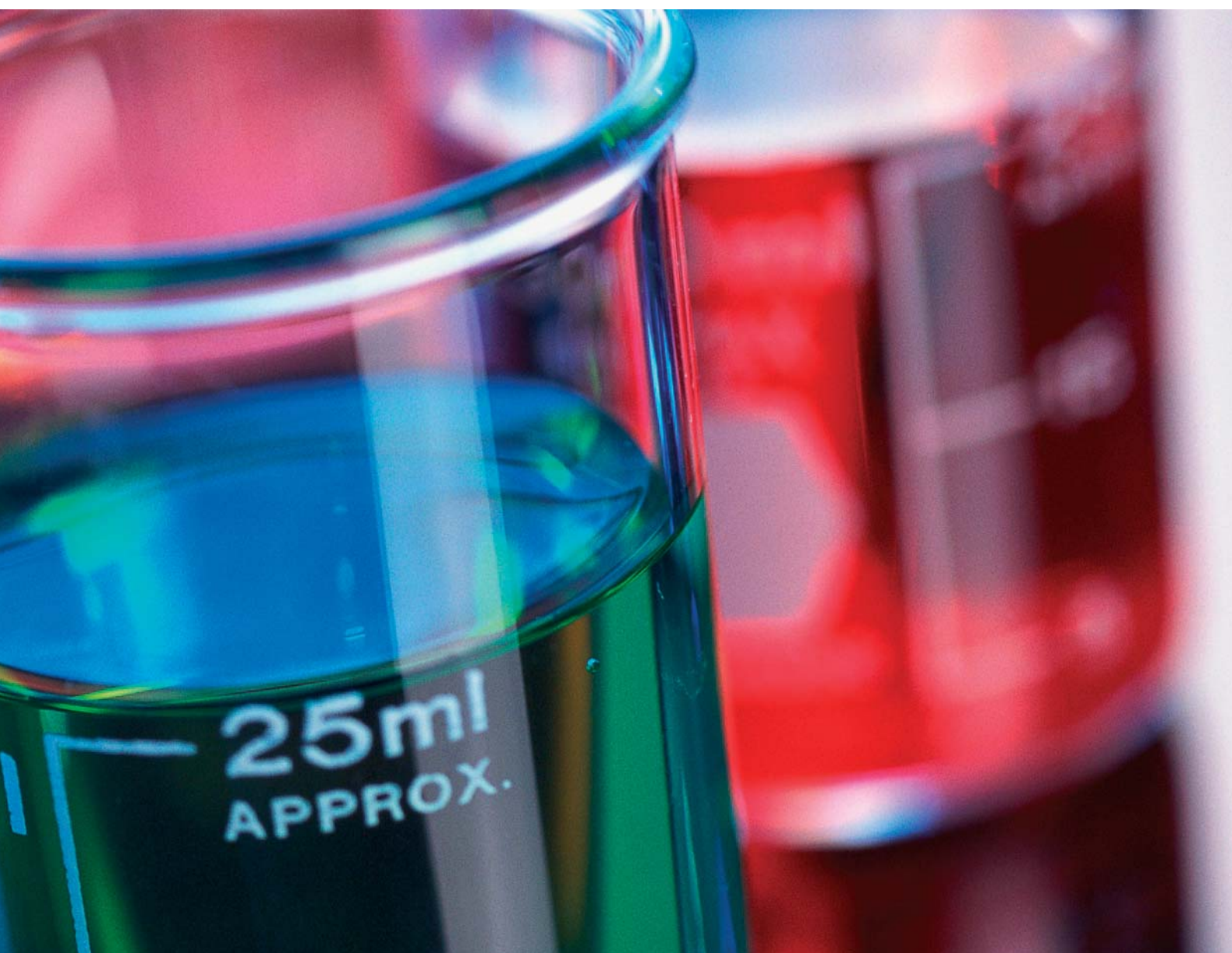

Boerger has Chemistry!

Production processes in the chemical industry depend heavily on robust and durable pumping systems. The wide range of pump sizes, the option loaded modular design and the peripheral equipment enable Boerger to supply a suitable Rotary Lobe Pump for your fluid handling application. BOERGER Rotary Lobe Pumps are manufactured to the European Explosion Proof Standard ATEX 100 a.

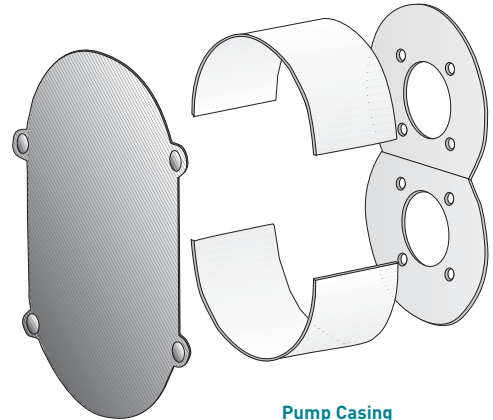

**Pump Casing
Protection Plates**
Optional materials from
Hardox, Stainless Steel,
Plastic or Ceramic

Variety of rotor designs
Customized solutions, e.g. entirely elastomer coated rotor or readjustable lobes, screw shape design for pulsation free operation, patented solutions with fast interchangeable rotor tips.

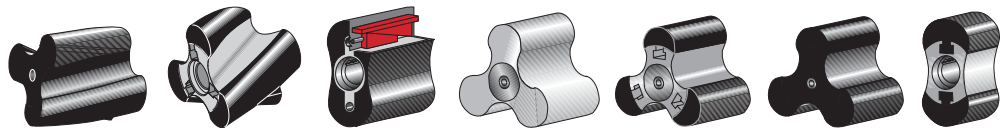

The Boerger MIP-Design is a unique advantage to minimize downtime and maintenance: MIP (Maintenance In Place) allows the quick and convenient replacement of all fluid wetted parts without removal of pipes, drives or other components of the pump unit by your own staff. Quick - Uncomplicated - Inexpensive.

Chemical fluids often include abrasive and aggressive characteristics. Wide viscosity ranges demand customized solutions for pumping systems: Boerger offers various shaft seals designs and rotor materials with different coatings (Elastomer, PTFE or Urethane) or solid stainless steel rotors. Casing protection plates are supplied with different steel, plastic or ceramic qualities.

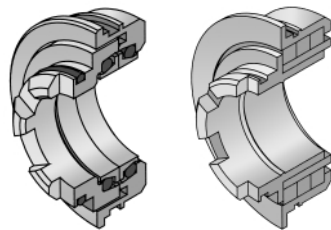

Shaft Seals
Quenched, reversible mechanical seal as standard, optional Multiseal or Packing

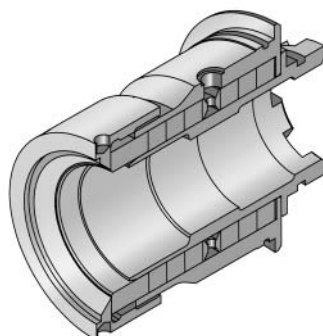

Worldwide unique
unique and exclusive
from Boerger:
Unrivalled MIP-Design
reduces life cycle cost
and downtime.





Epoxy and Polyester Resins | Transfer of fluids containing epoxy and polymer resins requires high quality wetted parts in pumping systems. Rubber coated rotors are not applicable. Boerger Rotary Lobe Pumps equipped with PTFE coated rotors accommodate this application. Further Boerger Pumps with stainless steel rotors are used for abrasive resin systems.

TECHNICAL SPECIFICATION

Pump Model	PL 100	PL 100
Flow Rate	8 m ³ /h	35 usgpm
Pressure	4 bar	58 psi
Power	3 kW	4 HP



Paint and Coatings | Mechanical Seals often have problems with coagulating liquids. Boerger developed the Multiseal, a special radial ring seal combination not requiring any flush systems. The cartridge type Multiseal is accessible through the quick release cover and is interchangeable with our standard seal.

TECHNICAL SPECIFICATION

Pump Model	AL 75	AL 75
Flow Rate	5-10 m ³ /h	22-44 usgpm
Pressure	3 bar	44 psi
Power	4 kW	5 HP



Raw Material for Detergent | Boerger supplied a Rotary Lobe Pump in a hazardous and explosion proof environment for transfer of raw material for detergents (3,000 cP). The pump is built from stainless steel with PTFE coated rotors.

TECHNICAL SPECIFICATION

Pump Model	PL 200	PL 200
Flow Rate	15 m ³ /h	66 usgpm
Pressure	5 bar	72 psi
Power	5,5 kW	7.5 HP



Sulfonate | A chemical plant was in need of a sulfonate positive displacement pump for a recently developed process. Boerger delivered a Rotary Lobe Pump with stainless steel casing and rotors. An integrated Vario Cap was added for over pressure protection.

TECHNICAL SPECIFICATION

Pump Model	FL 518	FL 518
Flow Rate	50 m ³ /h	220 usgpm
Pressure	12 bar	174 psi
Power	30 kW	40 HP



Fibrous Cement Mud | A self-priming pump unit was required to clean up a vacuum tank contaminated with fibrous cement mud. A robust Boerger Rotary Lobe Pump in MIP-Design was delivered to the customer. The replacement of axial and radial protection plates can be accomplished in a short time period.

TECHNICAL SPECIFICATION

Pump Model	PL 200	PL 200
Flow Rate	12 m ³ /h*	53 usgpm
Pressure	2 bar	29 psi
Power	3 kW	4 HP
Temperature	60-80°C	140-176°F



Various Paints | Boerger developed a mobile pump package on a cart for changing applications. The gooseneck flange design increases the suction capabilities of the Rotary Lobe Pump. A mechanically adjustable variable speed drive and a pneumatically operated control valve ensure high flow ratios.

TECHNICAL SPECIFICATION

Pump Model	PL 200	PL 200
Flow Rate	variable	variable
Pressure	6 bar	87 psi
Power	3 kW	4 HP



Polymer | Because of dry run and priming problems a rotary gear pump needed to be exchanged in a polymer application. Both dry run and self-priming capabilities are features of Boerger Rotary Lobe Pumps. Additionally the pump is equipped with over pressure protection.

TECHNICAL SPECIFICATION

Pump Model	AL 75	AL 75
Flow Rate	15 m ³ /h	66 usgpm
Pressure	2 bar	29 psi
Power	4 kW	5 HP

BÖRGER®

Börger GmbH

Benningsweg 24

46325 Borken-Weseke

Germany

Phone +49 (0) 28 62 / 91 03-0

Fax +49 (0) 28 62 / 91 03-46

info@boerger-pumps.com

www.boerger-pumps.com

